

rA1 = 0250	°F 1 = 0750	HLd1 = 00.00
rA2 = 0900	°F 2 = 1425	HLd2 = 00.30
rA3 = FULL	°F 3 = 1050	HLd3 = 00.00
rA4 = 0150	°F 4 = 0750	HLd4 = 00.00
rA5 = 0000		

- The display shows **Strt** after the final entry above.
- Press (Program) button one last time to start the firing. Display will show - **On-**

### Heat Treating Program Example

Below is a typical 3 step firing schedule for Heat Treating Steel.

- Heat as fast as possible from starting temperature to 1800°F, Hold at 1800°F for 20 minutes
- Cool as fast as possible from 1800°F to 400°F, with no hold time at 400°F
- Heat as fast as possible from 400°F to 500°F, Hold at 500°F for 5 hours, and then Shut-off

To program this schedule from **IdLE** mode;

- Press (Program) button. The controller will display the last active program that was used. **PrO1 – PrO9**
- Press (Program) button again if you want to use the same program that is shown or press (Increase) button to change to another program and then press (Program) button again.
- Program the steps below and press (Program) button after each segment.

rA1 = FULL	°F 1 = 1800	HLd1 = 00.20
rA2 = FULL	°F 2 = 0400	HLd2 = 00.00
rA3 = FULL	°F 3 = 0500	HLd3 = 05.00
rA4 = 0000		

- The display shows **Strt** after the final entry above.
- Press (Program) button one last time to start the firing. Display will show - **On-**



## Autofire® Express Ramp/Hold Controller Instruction Guide



This button is for selecting a firing program and advancing through the programming steps. After programming is complete, use this button to Start and Stop the firing.



This button is used to change the firing program during programming and to change the display values for specific program settings. During a firing, use this button for special firing options (including Skip Step).



This button is used to change the display values for specific program settings. It is also used to activate the Program Review feature.



When using the Increase and Decrease buttons to change number settings, the values will change more rapidly if the button is held in.

## Status Indicator Lights

3 lights are located to the right of the display.

- |           |                                       |
|-----------|---------------------------------------|
| Ⓞ Program | lit during controller programming     |
| Ⓞ Review  | lit during Program Review.            |
| Ⓞ Run     | lit (blinks) during an active firing. |

## Audible Alarm

The controller is equipped with a small buzzer that will sound during button presses and at the successful completion of a firing for 30 seconds. The alarm will also sound to notify you of diagnostic alarms that may occur during a firing. To silence an active buzzer, Press any button.

## Temperature display preference

All temperature displays on the controller can be viewed as °F (Fahrenheit) or °C (Celsius). The temperature display preference is set by positioning a small circuit board jumper on the back side of the controller that is labeled C/F. The C/F jumper has 2 pin positions, when installed on the 2 corresponding circuit board pins the controller will display all temperatures as °F(Fahrenheit). When no jumper is installed on the 2 circuit board pins the controller will display all temperatures as °C (Celsius). To determine if your controller is set for °F or °C without viewing the jumper position, the small decimal point light in the bottom right-hand corner of the display panel indicates °F or °C. If this decimal point light is lit, the controller is set for °C.

The C/F jumper position is shown on the wiring diagram included in this manual.

## Temperature Measurement

The controller monitors and controls temperature from a single Type K thermocouple sensor. Thermocouple probes extend into the firing chamber to measure the temperature. Use caution to avoid damage to the system thermocouple. If the probe is damaged, the controller may not function properly.

## Temperature Control

The controller heats the firing chamber by turning relays on and off at the appropriate rate to maintain the program schedule. It is normal to hear the clicking noises associated with turning relays on and off throughout the firing.

## Understanding Firing Programs

Orton controllers require 3 variables for each heating or cooling step of a firing schedule. These variables are;

1. Heating or cooling rate (Speed)
2. Heating or cooling temperature
3. Hold time (Soak) at heating or cooling temperature.

## Ceramic Glaze (Cone06) Firing Program Example

Below is a typical 4 step firing schedule for Ceramic Glaze Firing to Cone06.

- Step 1. Heat from starting temperature to 1031°F at 360°F/Hour, with no Hold time at 1031°F
- Step 2. Heat from 1031°F to 1103°F at 180°F/Hour, with no Hold time at 1103°F
- Step 3. Heat from 1103°F to 1675°F at 297°F/Hour, with no Hold time at 1675°F
- Step 4. Heat from 1675°F to 1828°F at 108°F/Hour, with no Hold time at 1828°F, then Shut-off

To program this schedule from **IdLE** mode;

1. Press (Program) button. The controller will display the last active program that was used. **PrO1 – PrO9**
2. Press (Program) button again if you want to use the same program that is shown or press (Increase) button to change to another program and then press (Program) button again.
3. Program the steps below and press (Program) button after each segment.

rA1 = 0360	°F 1 = 1031	HLd1 = 00.00
rA2 = 0180	°F 2 = 1103	HLd2 = 00.00
rA3 = 0297	°F 3 = 1675	HLd3 = 00.00
rA4 = 0108	°F 4 = 1828	HLd4 = 00.00
rA5 = 0000		

4. The display shows **Strt** after the final entry above.
5. Press (Program) button one last time to start the firing. Display will show - **On-**

## Glass Fusing/Slumping Firing Program Example

Below is a typical 4 step firing schedule for Glass Slumping or Fusing.

- Step 1. Heat from starting temperature to 750°F at 250°F/Hour, with no Hold time at 750°F
- Step 2. Heat from 750°F to 1425°F at 900°F/Hour, Hold at 1425°F for 30 minutes
- Step 3. Cool as fast as possible from 1425°F to 1050°F, with no Hold time at 1050°F
- Step 4. Cool from 1050°F to 750°F at 150°F/Hour, and then Shut-off

To program this schedule from **IdLE** mode;

1. Press (Program) button. The controller will display the last active program that was used. **PrO1 – PrO9**
2. Press (Program) button again if you want to use the same program that is shown or press (Increase) button to change to another program and then press (Program) button again.
3. Program the steps below and press (Program) button after each segment.



## Programming Hold Time

Each step of a firing program can have an optional Hold time. Hold time is the amount of time you want to stay at the previously determined heating or cooling temperature. Hold time is also referred to as Soak or Dwell time.

Hold Time is entered in Hours & Minutes format. The middle decimal point light on the controller display is used to separate Hours from Minutes. For Example, A 1 hour hold time should be set like [01.00], while a 1 hour and 30 minute hold time would be [01.30]. If no hold time is desired, the setting should be [00.00]

A special Hold time is available for indefinite Hold periods. If it is desired to hold the program temperature until someone manual stops the firing or manually advances the program, a hold time of [99.59] represents indefinite Hold.

The value range available for setting Hold time is 00.00 to 99.58.

During a firing, the hold time begins as soon as the temperature reaches the heating or cooling temperature. As the hold time progresses, the controller display will count-down the remaining time until the hold time has expired.

During programming the display prompts for all Hold settings is **HLd** followed by the step number like **HLd1**, **HLd2**, **HLd3**, etc...

## Other Programming Notes

After a firing program is set in the controller, the values will not change or be lost when the controller is turned off.

It is not possible to back-up in the programming mode. If a mistake is made while programming a previous step, you must start over from the **IdLE** mode to make corrections.

If no buttons are pressed for 1 full minute during programming, the controller will automatically exit the program mode and return to the **IdLE** display. During a firing, if the options menu is activated for programming, the controller will return to the active display if no buttons are pressed for 1 full minute.

## Delay Start Option

Prior to the active start of any firing, the controller display will show a Start prompt of **Strt**. This appears after the firing program selection and programming. If a delay start time is desired, press the Decrease/Review button to activate a delay start prompt. The display will show **dELA** alternating with the adjustable delay time in Hours & Minutes format. Use the Increase/Decrease buttons to set the Delay time and then press the Program button to return to the **Strt** prompt. When you are ready to begin the delay period, press the Program button again.

Delay time counts-down on the controller display before the actual start of the firing. When the delay time expires, the actual firing program begins automatically. The Delay time has a setting range of 00.00 (no delay) to 99.59 (99 hours. 59Minutes)

the wiring for the thermocouple and the physical condition of the probe inside the firing chamber.

**FtL** - This alarm indicates that the firing was taking too much time to complete and the firing was terminated. The controller monitors the deviation from the desired firing schedule as compared with the actual firing results. There are 2 conditions for the **FTL** alarm.

1. The heating or cooling rate is slower than 27°F (15°C) per Hour
2. The current program step has lasted 2 hours longer than anticipated.

In most cases, the **FTL** alarm occurs during heating if the heating rate is set to a fast speed that cannot be maintained by the kiln. If the heating rate is within the systems capability, a component failure has probably occurred with the heating elements or the heater relays.

During cool-down, a well insulated system will have cooling limitation and rapid cooling rates may set off this alarm if the cooling speed cannot be maintained. Increasing the final cool-down temperature or slowing the programmed cooling rate can avoid this alarm.

**tCL** - This alarm indicates that the thermocouple signal is not responding to the demand for more system power during heat-up. There are 3 conditions for the **tCL** alarm.

1. The heating rate is slower than 9°F (5°C) per Hour
2. The actual kiln temperature is lagging behind the desired setpoint temperature by more than 100°F (56°C).
3. The actual temperature is less than 500°F (260°C)

In all cases, the **tCL** alarm occurs during heating when little temperature rise is detected. This can be the result of a component failure; most likely a failed heating elements or a heater relay. Another possible problem is with the thermocouple sensor signal; if the thermocouple probe is not properly positioned in the firing chamber or if the wiring from the thermocouple has short-circuited the controller will not detect actual temperature changes in the firing chamber.

**EtH** - This alarm indicates that the Electronics temperature is too hot for controller operation. The controller temperature must be below 176°F (80°C) to prevent damage to the electronic components. The ETH alarm cannot be cleared unless the board temperature has cooled. If the ETH occurs frequently, check the kiln for heat loss near the controller. Proper venting and heat-shielding should be inspected.

**HtdE** -The High Temperature deviation alarm sounds an audible alarm and terminates the firing if the actual kiln temperature is above the controller set-point by 56°C (100°F). This alarm is active only when the actual kiln temperature is above 500°F (260°C)

## Status Display Codes

Below is a list of normal display codes which indicate the controller mode of operation.

**IdLE** - This is ready mode; No firing in process. This message will alternate with the temperature display and/or any alarm messages that may occur.

**dELA** - This is the delay start mode. This message will alternate with the delay time count-down if programmed.

**Strt** - This is a final prompt before starting a new firing. The Delay start and Thermocouple Offset features are accessed from this prompt.

**-On-** - This is a short (5 second) display that indicates a new firing has been started.

**StOP** - This is an Abort message; the firing was stopped early. This message will alternate with the temperature display and/or any alarm messages that may occur.

**CPLt** - This is a firing complete message; the firing ended successfully. This message will alternate with the temperature display and the total firing time from start to finish.

**x-4** - This is a short (5 second) display of the Model number which appears every time the controller is turned on.

## Alarm Display Codes

In addition to Power failure alarms, these messages may be displayed if the controller detects a problem during the firing.

**tC** - This alarm indicates that the thermocouple sensor is no longer detected. The controller can not operate without a thermocouple signal. In most cases, the thermocouple has failed and will need replacement, or the electrical connections for the thermocouple may be loose or damaged. Check the wiring for the thermocouple and the physical condition of the probe inside the firing chamber.

**tCr** - This alarm indicates that the thermocouple sensor is detected but the signal is reversed. The firing was terminated. The thermocouple signal is a low voltage direct current with +/- polarity. The controller will sense that the temperature is traveling backwards from what is expected. In most cases, the thermocouple needs reconnected properly. Check the wiring for the thermocouple.

**FAIL** - This alarm indicates that the thermocouple sensor is no longer detected. The signal was lost during and active firing and the firing was terminated. The controller can not operate without a thermocouple signal. In most cases, the thermocouple has failed and will need replacement, or the electrical connections for the thermocouple may be loose or damaged. Check

An active delay time can be canceled by pressing the Program/Start button any time during the delay count-down to begin the actual firing.

## Thermocouple Offset Option

Thermocouple Offset allows you to correct the temperature display a few degrees in a positive or negative direction. This can improve the controller accuracy if the thermocouple probe is aged or if the firing results appear to be slightly under or over fired. This offset allows you to make minor adjustments to the firing temperatures without changing the programmed heating or cooling temperatures.

Prior to the active start of any firing, the controller display will show a Start prompt of **Strt**. This appears after the firing program selection and programming. If a thermocouple offset is desired, press the Increase/Option button to activate a thermocouple offset prompt. The display will show **tCOS** alternating with the adjustable offset value. Use the Increase/Decrease buttons to set the Offset and then press the Program button when you are ready to return to the **Strt** prompt.

Thermocouple offset (**tCOS**) has a limited offset range of +/-20°F (+/-11°C). A positive correction will increase the controller display temperature by the amount selected. This will make the firing temperatures lower. A negative correction will decrease the controller display temperature by the amount selected, making the firing temperatures higher.

## Program Review

Any time during an active firing, the Program Review feature can be activated to show you the complete firing schedule on the controller display. Press the Decrease/Review button to activate the Program Review. Each segment of your firing schedule will scroll automatically on the display for a few seconds each. To cancel the Review in process, simply press any button.

Program Review can also be activated when the controller is **IdLE** or during program selection. After this type of Program Review, the controller advances directly to the **Strt** prompt. The Review can be used to bypass making any changes to the current firing schedule.

## Program Recall

Program Review can be used to quickly select any firing schedule that is already programmed into the controller memory. To select a saved program, the controller should first be at the **IdLE** prompt. Press the Increase/Option button until the display shows the desired program, then press the Decrease/Review button to automatically load the program and to review the program settings. At the end of automatic program review, the controller will go directly to the **Strt** prompt and the firing can be started with one more press of the Start/Stop button. Only use the quick program recall to start a new firing if no changes are required for the entire firing program.

## Options Menu

During an active firing, the Increase/Option button will activate an options menu and scroll through the available options with each button press. These

options allow you to make adjustments to the firing program without stopping the firing. The available options follow.

### Skip Step

During an active heating, cooling or hold time, it is possible to skip ahead to the next program step. Press the Increase/Option button to display the Skip Step prompt **SStP**. Then Press the Program button to display the current ramp or hold segment. Press the Program button again to initiate the Skip and the controller display returns to the normal firing mode. If the Decrease/Review button is pressed, the Skip function is canceled and the controller display returns to the normal firing mode.

The Skip function can be used to end a Hold time early or to skip from any heating/cooling step to the next heating/cooling step. The Skip function does nothing during the final program step. To end a final program step, simply press Stop.

### Add Hold Time

During an active heating, cooling or hold time, it is possible to permanently add more Hold time to the current program step. Press the Increase/Option button until the Hold Time prompt **HLdt** is displayed. Then Press the Program button to display the current hold time. Press the Increase/Option button to add 5 minute increments to the original Hold time. Then press the Program button to return to the normal firing mode. If the Decrease/Review button is pressed while the **HLdt** prompt is displayed, the controller display returns to the normal firing mode.

### Change Heating/Cooling Temperature

During an active heating, cooling or hold time, it is possible to make permanent changes to the heating or cooling temperature of the current program step. Press the Increase/Option button until the Change Temperature prompt **CHGt** is displayed. Then press the Program button to display the current temperature setting. Adjust the temperature setting with the Increase or Decrease buttons. Then press the Program button to return to the normal firing mode. If the Decrease/Review button is pressed while the **CHGt** prompt is displayed, the controller display returns to the normal firing mode.

### Threshold Alarm

During The firing, it is possible to set an audible alarm and display alarm for when the actual temperature reaches a specified value. The buzzer will sound and the display will show the alarm code **ALAr**.

To set the alarm, Press Increase/Option button during the active firing until the alarm prompt **ALAr** is displayed. Then Press the Program button to display the current alarm temperature setting. Adjust the temperature setting with the Increase or Decrease buttons. Then press the Program button to return to the normal firing mode. If the Decrease/Review button is pressed while the **ALAr** prompt is displayed, the controller display returns to the normal firing mode.

The alarm is disabled (turned off) when the alarm value is set to 32°F (0°C). The alarm value can be reset or changed many times during a single firing. To silence an active alarm, simply press any button. The maximum programmable value for the alarm is 2400°F (1316°C). If the controller does not allow you to program alarm temperatures up to 2400°F/1316°C, it has been factory set by the supplier to a lower safety temperature. This is often necessary to limit the controller to the maximum operating temperature of the system.

### Flow Diagram for Options Menu

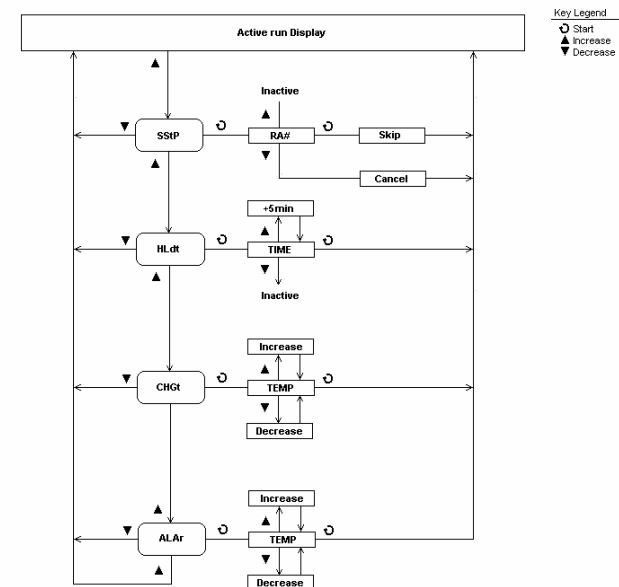

### Power Fail Recovery

A firing will resume after a power interruption if certain conditions are met.

1. The controller was not performing a cooling step and the cooling temperature was not exceeded. If so, the display will show the alarm code **PF 1** and terminate the firing.
2. When power is restored the actual temperature must be above 212°F (100°C). If not, the display will show the alarm code **PF 2** and terminate the firing.
3. When power is restored, the temperature drop during the power interruption must be less than 72°F (40°C). If not, the display will show the alarm code **PF 3** and terminate the firing.